

QS200 SERIES

INSERTION ULTRASONIC FLOW METER



The QS200 Insertion Ultrasonic Flow Sensor provides an accurate reading of liquid flow rate and accumulated flow. Designed to support commercial irrigation applications, the QS200 is available in five pipe sizes, 1 to 4 in.

Can be a drop-in replacement for most insert paddle wheels that have been installed in a gray schedule 80 PVC tee (1.5" -4" tee) with a quick release pin. Recommend tee and sensor replacement to ensure complete functionality and minimize false readings or fitment issues.

FEATURES / BENEFITS

- Low-cost, effective and easy installation
- No moving mechanical parts (low-maintenance)
- Simple two-wire connector (for power and pulse)
- Compatible with most irrigation controllers that have a flow sensor input. See our QS200 K-factor calculator for controller compatibility. <https://greatplainsindustries.com/pages/qs200-k-factor-calculator>
- High accuracy: $\pm 2.0\%$ of reading (compared to full scale accuracy)
- Provides extended leak detection down to 0.1 fps (0.03 m/s)
- LED light indicators: (green for power and amber for pulse)
- Patented design
- Certified NSF61 option for those applications where potable water regulations must be met (PW models)
- External wiring: (direct burial wire)

SPECIFICATIONS

Tee Housing Material:	Schedule 80 PVC
Insert Wetted Materials:	Body: PPS (Ryton® R-4)
	Sensor: PEI (Ultem 1000)
	O-Ring: EPDM
Temperature Rating:	
Operating:	32° F to 140° F (0° C to 60° C)
Storage:	-20° F to +160° F (-29° C to +71° C)
Flow Range:	0.1 to 15 fps (0.03 to 4.6 m/s)
Accuracy:	Typically $\pm 2\%$ of reading
Operating Pressure:	203 psi @ 73° F (14 bar @ 23° C)
	150 psi @ 140° F (10 bar @ 60° C)
Transducer Excitation:	Supply Voltage: 7.5V (dc) min. to 36V (dc) max
	Quiescent Current: 200 μ A (typical)
Output Frequency:	0 to 100 Hz
Output Pulse Width:	4 ms
Electrical Cable for Insert Electronics:	36 inches (914.4 mm) of 18 AWG, solid copper, "Direct Burial" (UL 493 & 83)

APPLICATIONS

- Turf / Landscape Irrigation Systems
- Agriculture Irrigation
- Micro Irrigation Systems
- Groundwater Monitoring
- Reclaimed (Recycled) Water
- Greywater

CERTIFICATIONS

NSF Certification for PW models only

IP68



Certified to NSF/ANSI 61-G & 372

INSERT DESCRIPTION

Designed for above and below grade applications, such as irrigation, municipal and underground monitoring where the flow rates are between 0.1 to 15 fps (0.03 to 4.6 m/s) and temperatures are below 140° F (60° C). QS200 inserts are supplied with two single conductors, 18 AWG solid copper wire leads that are 36 inches (914.4 mm) in length with UL Style 116666 direct burial insulation.

PRODUCT CONFIGURATION

1 PRODUCT IDENTIFIER:

QS200 = QS200 Insertion Ultrasonic Flow Sensor

2 METER SIZE:

Blank = Insert Only
-10 = Schedule 80 PVC Tee – 1 inch
-15 = Schedule 80 PVC Tee – 1-½ inch
-20 = Schedule 80 PVC Tee – 2 inch
-30 = Schedule 80 PVC Tee – 3 inch
-40 = Schedule 80 PVC Tee – 4 inch

3 NSF CERTIFICATION:

Blank = None
PW = Potable Water Version (NSF Certified)

1 2 3
 --->>> QS200 -10 PW

FLOW INSERT SELECTION CHART

Flow Sensor Model	Pipe Size	Operating Range (Min.)	Operating Range (Max.)	Adjoining Pipe	Typical ¹ K-Factor	Hydrawise® ² K-Factor (Litres/Pulse)	Rain Master® K-Factor	Offset	Reference	
									Pulses/Gal	Pulses/Litre
QS200-10	1 in.	0.22 GPM (0.83 L/min) 0.1 ft/sec	33 GPM (124.92 L/min) 15 ft/sec	Sch 40	0.5575	0.0352	152	0	107.62	28.43
				Sch 80	0.5354	0.0338	146	0	112.06	29.60
QS200-15	1-½ in.	0.55 GPM (2.08 L/min) 0.1 ft/sec	82 GPM (310.41 L/min) 15 ft/sec	Sch 40	0.7923	0.0500	216	0	75.73	20.00
				Sch 80	0.7860	0.0496	214	0	76.34	20.17
QS200-20	2 in.	0.92 GPM (3.48 L/min) 0.1 ft/sec	138 GPM (522.39 L/min) 15 ft/sec	Sch 40	1.4610	0.0922	398	0	41.07	10.85
				Sch 80	1.4568	0.0919	397	0	41.19	10.88
QS200-30	3 in.	2.06 GPM (7.80 L/min) 0.1 ft/sec	309 GPM (1169.70 L/min) 15 ft/sec	Sch 40	4.2630	0.2690	1163	0	14.07	3.72
				Sch 80	4.0850	0.2577	1114	0	14.69	3.88
QS200-40	4 in.	3.58 GPM (13.55 L/min) 0.1 ft/sec	537 GPM (2032.78 L/min) 15 ft/sec	Sch 40	8.0881	0.5103	2206	0	7.42	1.96
				Sch 80	7.9062	0.4988	2156	0	7.59	2.00
QS200	Insert Only			Sch 80	Use pipe size to determine value			0	Use pipe size to determine value	

DIMENSIONS

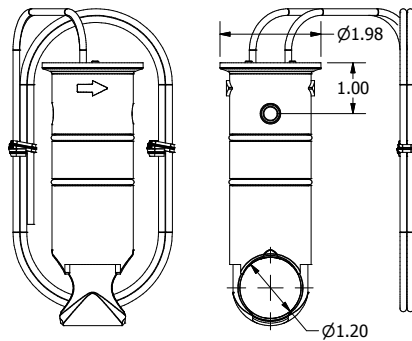

¹ Controller Brands: Baseline™, Calsense, Hunter®, HydroPoint® (WeatherTrak®), Rain Bird®, Toro®, © Tucor, and Weathermatic®. ² Hydrawise®HCC models only.

K-Factor Information:

NOTE: The meter size is molded on the vertical stem of the Tee.
FLOMEC ultrasonic meters use K-Factor plus offset numbers for greater accuracy during calibration. These values are derived by calibrating the meters using NIST traceable instrumentation. Using both sets of values to calibrate the meters provides greater accuracy than using only a K-factor value. The K-factor and offset values for each meter are listed above.

IMPORTANT: The K-factors provided are for reference. Accuracy can be affected by plumbing configuration, fluid condition, adjoining pipe schedule, type of meter tee (non-FLOMEC brand), and entrapped air. Customers should always validate accuracy and adjust K-factor as needed. If using non-FLOMEC tees, K-Factor will be different than those shown. Inconsistencies with these tees affect any stated value. Customers must verify accuracy if concerned.

QS200 INSERT

1, 1-1/2, & 2 INCH METERS

	QS200-10, QS200-10PW 1 INCH	QS200-15, QS200-15PW 1-1/2 INCH	QS200-20, QS200-20PW 2 INCH
A. Length	4.25 in. (108mm)	4.90 in. (124mm)	5.56 in. (141mm)
B. Height	5.38 in. (137mm)	5.63 in. (143mm)	6.12 in. (156mm)
C. Width (at widest point)	2.50 in. (64mm)	2.50 in. (64mm)	2.88 in. (73mm)
D. Depth	4.47 in. (114mm)	4.47 in. (114mm)	4.94 in. (125mm)

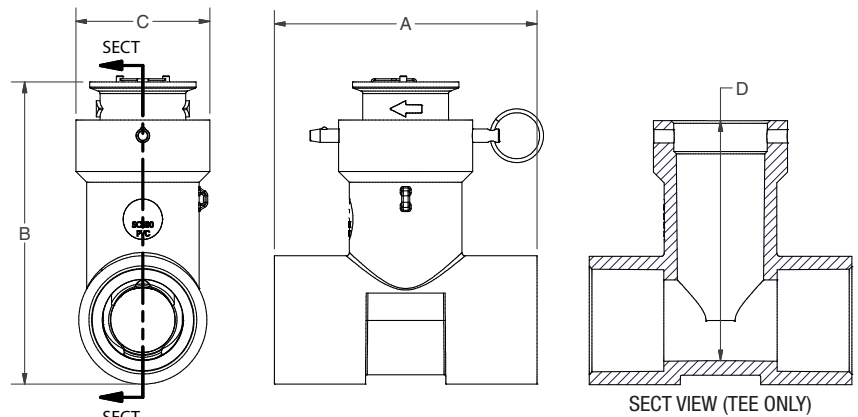

3 & 4 INCH METERS

	QS200-30, QS200-30PW 3 INCH	QS200-40, QS200-40PW 4 INCH
A. Length	6.63 in. (168mm)	7.38 in. (187mm)
B. Height	7.20 in. (183mm)	8.41 in. (213mm)
C. Width (at widest point)	4.18 in. (106mm)	5.23 in. (133mm)
D. Depth	4.91 in. (124mm)	6.17 in. (156mm)

